

**DADO LIBERO PER OGIVA A SALDARE**

Filetto Gas Cilindrico

**FREE NUT FOR WELD ON NIPPLE**

Thread BSP

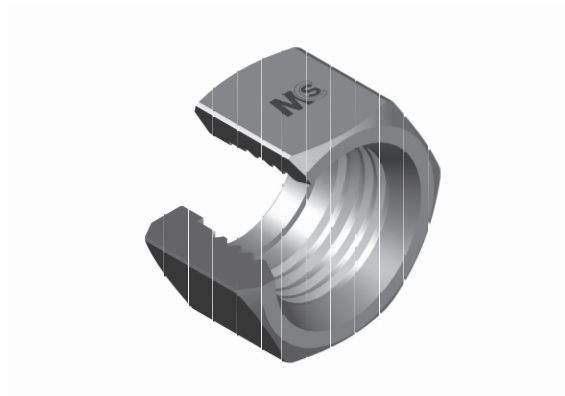
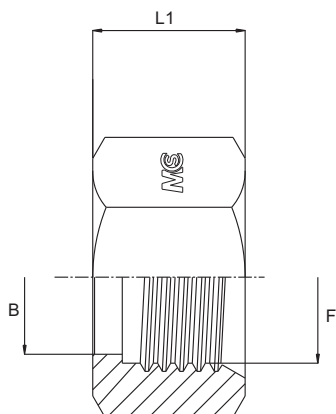

Bar W.P.	Codice Part Number	F	B	L1
300	DGL02	1/8"	-	-
	DGL04	1/4"	9,8	14,5
	DGL06	3/8"	13,0	17,0
200	DGL08	1/2"	16,0	18,0
	DGL12	3/4"	22,0	20,0
120	DGL16	1"	28,1	22,0
105	DGL20	1" 1/4	34,0	23,0
	DGL24	1" 1/2	41,2	23,0
70	DGL32	2"	54,2	32,0