

**ADATTATORE DIRITTO MASCHIO A SALDARE**

Filetto Gas Cilindrico con Tasca

**MALE STRAIGHT WELDING ADAPTOR**

Thread BSP with groove

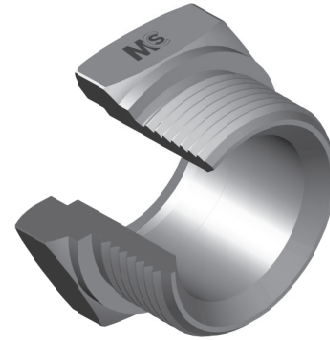
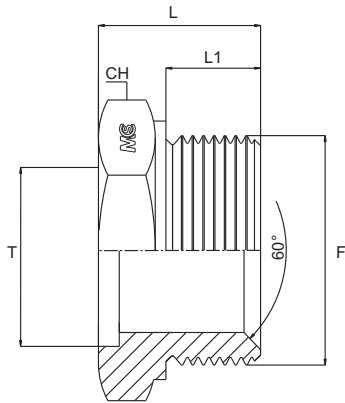

Bar W.P.	Codice Part Number	F	D	L1	T	L	CH
300	BSPWM02T08	1/8"	4,0	8,0	8,0	16,0	14
	BSPWM04T10	1/4"	6,3	11,0	10,0	19,5	19
	BSPWM06T12	3/8"	8,0	12,0	12,0	21,5	22
200	BSPWM08T16	1/2"	12,0	14,0	16,0	24,0	27
	BSPWM12T25	3/4"	17,0	16,0	25,0	27,0	32
120	BSPWM16T26	1"	22,0	19,0	26,0	32,0	41
105	BSPWM20T32	1" 1/4	30,0	20,0	32,0	33,5	50
	BSPWM24T38	1" 1/2	35,0	20,0	38,0	34,5	55
70	BSPWM32T46	2"	44,0	24,5	46,0	39,0	70